

Thank you for purchasing the Dial Bore Gauge.
Please read this manual thoroughly before use for proper operation.

■ PART IDENTIFICATION

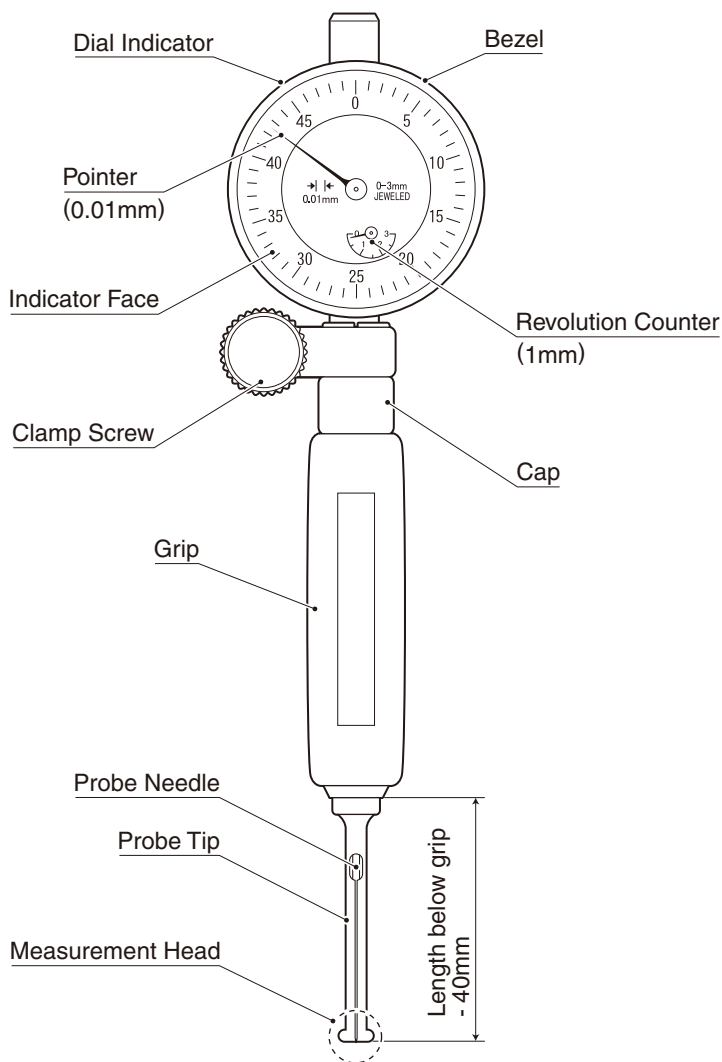

■ SPECIFICATIONS * : Including supplied Dial Indicator.

Model No.	CDI-6
Measuring Range (mm)	4 ~ 6
Graduation (mm)	0.01
* Wide Range Accuracy (μm)	10
* Adjacent Error (μm)	5
* Repeat Accuracy (μm)	3
Single Probe Measuring Range (mm)	0.6
Weight (g)	165

ACCESSORIES

4 Probe Tips
for following Range..... 4.0 ~ 4.6mm
4.5 ~ 5.1mm
5.0 ~ 5.6mm
5.5 ~ 6.1mm

Probe Needle..... 1 (Note: At time of purchase
Probe Needle is inserted into
Measurement Head)

Spanner..... 1

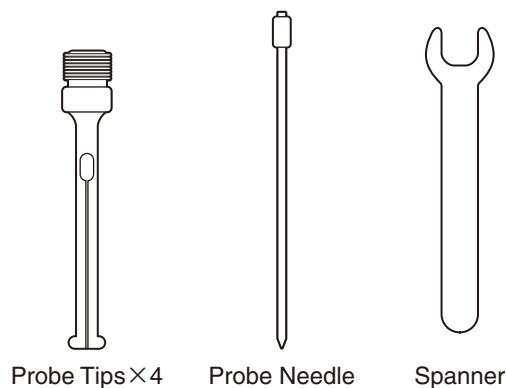

■ ASSEMBLY

① Loosen the Clamp Screw and insert the Dial Indicator until the Pointer rotates 1/10 turn or more. Secure by tightening the Clamp Screw.

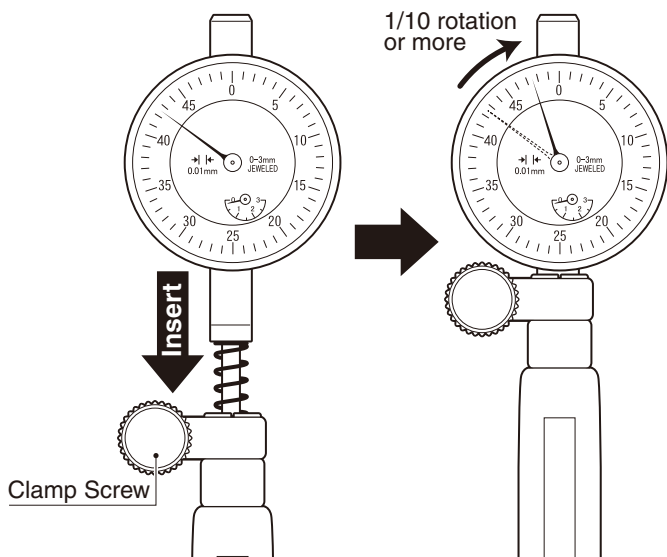

② Insert the Probe Needle into the Probe Tip and screw onto the end of the gauge body. Using Spanner, tighten to secure.

※ Change Probe Tip as required to match the required measurement range.

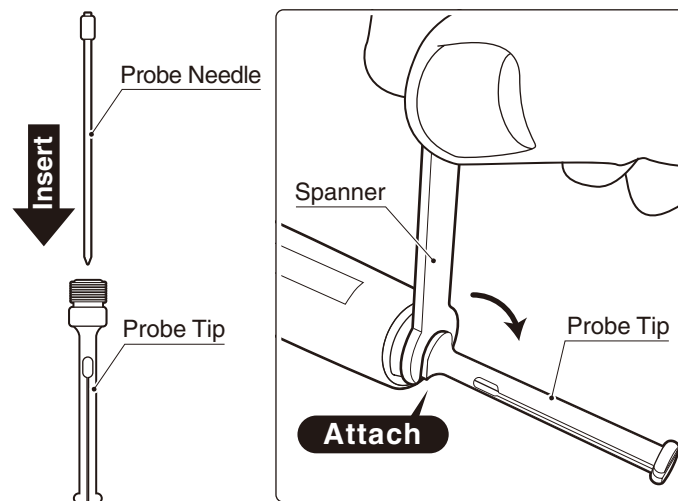

OPERATION

※Before use, please make sure the Probe Tip is securely fastened to the gauge body. Tighten as necessary.

ZERO POINT ADJUSTMENT

- ① Prepare a ring gauge to use as a reference standard for setting the zero-point. Insert the Measurement Head into the ring gauge.
- ② In cross section perpendicular to the axis of the ring gauge, position the gauge along diameter a (Figure:1). This is the maximum distance, and at this point the Dial Indicator will read the minimum value. The Gauge Head will automatically sit in this position when inserted.
- ③ In cross section parallel to the axis of the ring gauge through diameter a , position the indicator to minimize the distance b (Figure:2). In this position the Dial Indicator will read the maximum value. This position must be manually achieved by moving the indicator and noting the point where the Pointer shows the maximum value. (Figure:3)
- ④ The reading obtained at step ③ is the zero-point. Rotate the bezel of the gauge until the Pointer is at the zero-point of the Indicator Face. (Figure:4)

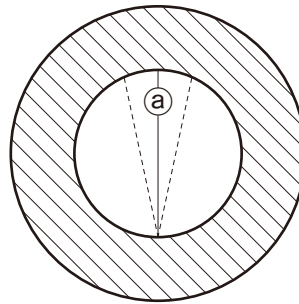

(Figure: 1)

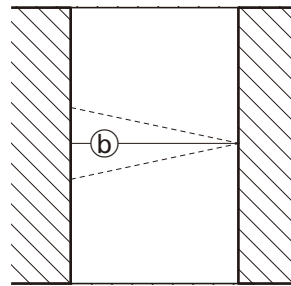

(Figure: 2)

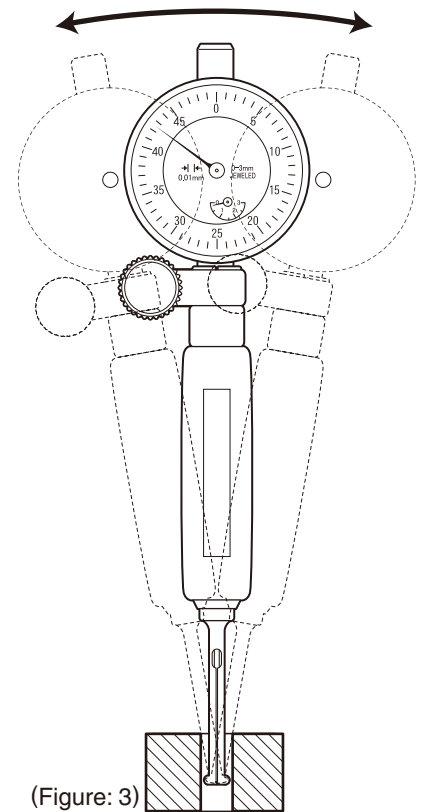

(Figure: 3)

MEASUREMENT

Insert the Measurement Head of the Dial Bore Gauge into the object to be measured. As in step ③ of "Zero-Point Adjustment" above, pivot the gauge while checking the pointer to determine the diameter b where the indicator will show the maximum value to determine the measurement reading. This reading is the difference between the measured value and the reference ring gauge.

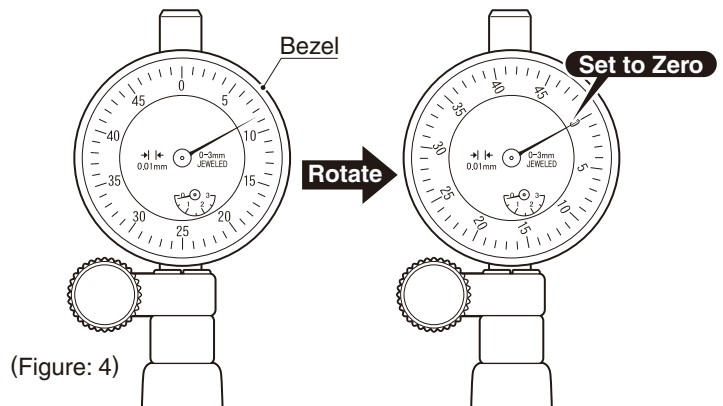

(Figure: 4)

NOTICE

- This is a precision instrument, use care not to drop or mishandle.
- Please do not disassemble or modify.
- Keep instrument away from water and oil.
- Use only with provided Probe tip and Probe Needle.
- Keep instrument away from direct sunlight or high temperatures such as in a car, or near a stove or heat source.
- Remove dust and cutting chips after use and apply rust preventative oil to Probe Tip and Probe Needle. When not in use store in original storage case.
- This product is for measuring inside diameter. Use only as directed. Improper use may cause accident or injury.

REPAIRS AND SERVICE

- If Gauge does not operate properly, or if you have any questions, please contact distributor or place of purchase.
- Please note, manufacturer is unable to respond to inquires or provide service directly. Please contact distributor or place of purchase.

SK Niigata seiki Co., Ltd.

6-15-22, Tsukanome, Sanjo, Niigata, Japan, 955-0055
 Tel. : +81-256-31-5660 Fax. : +81-256-39-7730
 MAIL: intl.sales@niigataseiki.co.jp
 URL http://www.niigataseiki.co.jp